



BMA Jack Slide-On Connector Solder Attachment 2 Hole Flange Mount for RG402, PE-SR402AL, PE-SR402FL, PE-SR402FLJ, PE-SR402TN

RF Connectors Technical Data Sheet

PE45327

Configuration

- Slide-On BMA Jack Connector
- 50 Ohms
- Straight Body Geometry
- RG402, PE-SR402AL, PE-SR402FL, PE-SR402FLJ, PE-SR402TN Interface Type
- Solder/Solder Attachment
- 2 Hole Flange

Features

- Max. Operating Frequency 22 GHz
- Good VSWR of 1.27:1
- Gold Plated Beryllium Copper Contact
- Blind Mate Connector
- IP54(Mated)
- Low-Engagement Force
- Radial and Axial Float Versions

Applications

- General Purpose Test
- Rack and Panel Mount Applications
- Custom Cable Assemblies
- Blind Mating
- Rack and Panel
- Phased Array Systems
- Base Stations
- RF Backplanes
- Test I/O

Description

Pasternack's PE45327 BMA jack slide-on 2 hole flange mount connector with solder/solder attachment for RG402, PE-SR402AL, PE-SR402FL, PE-SR402FLJ and PE-SR402TN is part of our full line of RF components available for same-day shipping. Our BMA jack connector operates up to a maximum frequency of 22 GHz and offers good VSWR of 1.27:1. The Pasternack blind mate connector is ideal for applications where direct visual or tactile access to the connection point is not possible, for example, when two circuit boards need to be mated. This BMA 2 hole flange connector allows designers to create external connections on their product enclosures, and can be used in a variety of other rack mount and panel mount applications.

Our BMA jack 2 hole flange connector PE45327 datasheet specifications and drawing with dimensions are shown below in this PDF. Pasternack's broad catalog of RF, microwave and millimeter wave connectors allows designers to configure and customize their signal connections however they like. Whether the need is to provide an I/O for a board design, or simply create a custom cable assembly configuration, Pasternack has the right connector for the job. Pasternack can also expertly build your custom cable assemblies for you and ship same-day.

Electrical Specifications

Description	Minimum	Typical	Maximum	Units
Frequency Range	DC		22	GHz
VSWR			1.27:1	
Insertion Loss			0.14	dB
Operating Voltage (AC)			350	Vrms
Dielectric Withstanding Voltage (AC)			1,000	Vrms
Insulation Resistance	5,000			MOhms

Click the following link (or enter part number in "SEARCH" on website) to obtain additional part information including price, inventory and certifications: [BMA Jack Slide-On Connector Solder Attachment 2 Hole Flange Mount for RG402, PE-SR402AL, PE-SR402FL, PE-SR402FLJ, PE-SR402TN PE45327](#)



BMA Jack Slide-On Connector Solder Attachment
2 Hole Flange Mount for RG402, PE-SR402AL, PE-
SR402FL, PE-SR402FLJ, PE-SR402TN

RF Connectors Technical Data Sheet

PE45327

Mechanical Specifications

Size

Length	0.7 in [17.78 mm]
Width/Dia.	0.74 in [18.80 mm]
Weight	0.011 lbs [4.99 g]
Mating Cycles	1,000 Cycles

Material Specifications

Description	Material	Plating
Contact	Beryllium Copper	Gold
Insulation	PTFE	
Outer Conductor	Beryllium Copper	Gold
Body	Brass	Tri-Metal

Mechanical Specification Notes:

Recommended axial float mount for best electrical performance: 0.51 +/- 0.25 mm (.020" +/- .010)

Environmental Specifications

Temperature

Operating Range	-40 to +100 deg C
Ingress Protection (IP) Rating	IP54(Mated)

Click the following link (or enter part number in "SEARCH" on website) to obtain additional part information including price, inventory and certifications: [BMA Jack Slide-On Connector Solder Attachment 2 Hole Flange Mount for RG402, PE-SR402AL, PE-SR402FL, PE-SR402FLJ, PE-SR402TN PE45327](#)



PE45327 CAD Drawing

BMA Jack Slide-On Connector Solder Attachment 2 Hole Flange Mount for
RG402, PE-SR402AL, PE-SR402FL, PE-SR402FLJ, PE-SR402TN

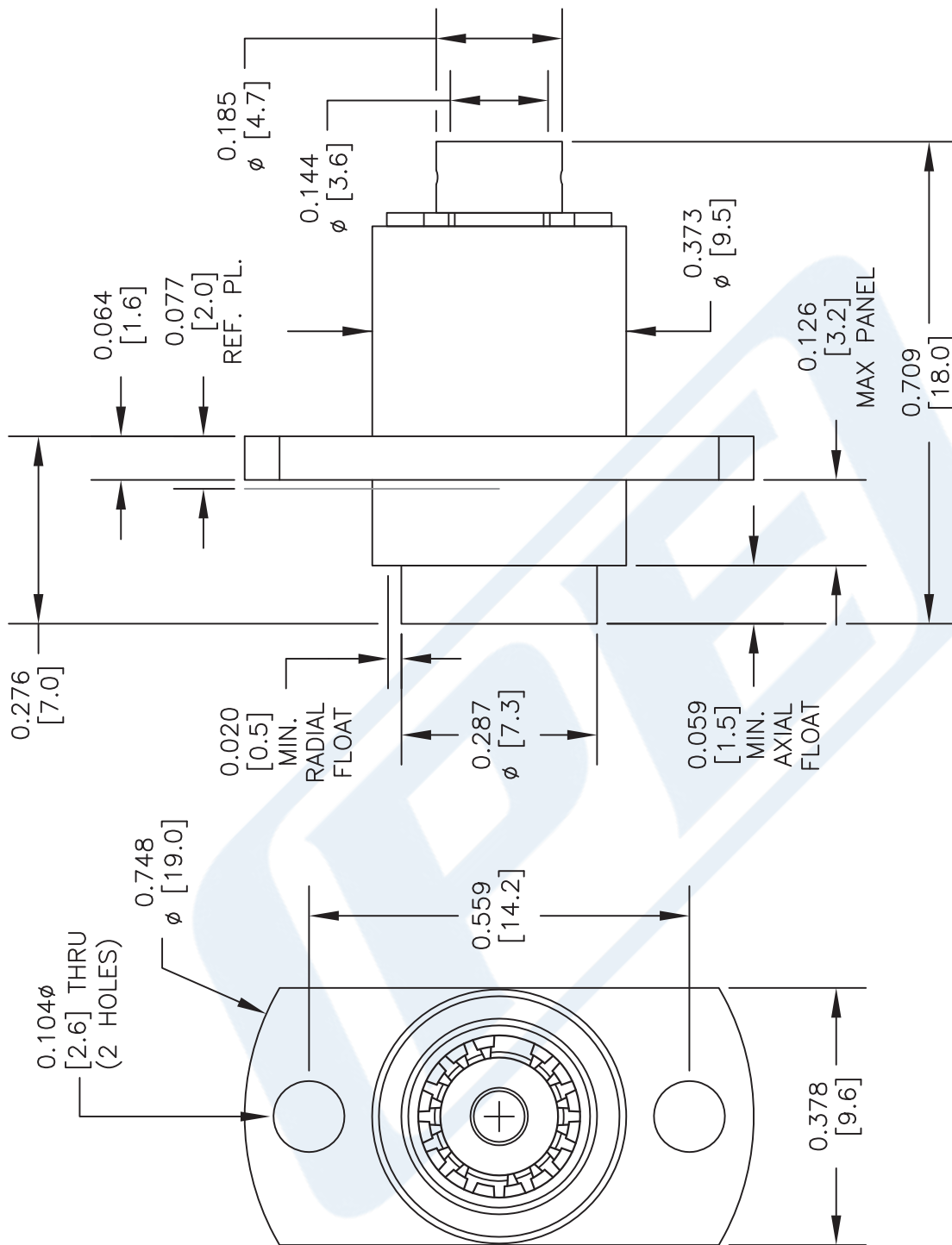

STANDARD TOLERANCES
 .X ±0.2
 .XX ±0.1
 .XXX ±0.05

*STANDARD TOLERANCES APPLY ONLY TO DIMENSIONS IN INCHES

NOTES:
 1. UNLESS OTHERWISE SPECIFIED ALL DIMENSIONS ARE NOMINAL.
 2. ALL SPECIFICATIONS ARE SUBJECT TO CHANGE WITHOUT NOTICE AT ANY TIME.
 3. DIMENSIONS ARE IN INCHES [mm].

DWG TITLE
PE45327

CAGE CODE **53919**

CAD FILE 020317

SCALE N/A

SIZE A

2233

PE PASTERNAK
 THE ENGINEER'S RF SOURCE

Pasternack Enterprises, Inc.
 P.O. Box 16759 | Irvine | CA | 92623

Phone: (949) 261-1920 | Fax: (949) 261-7451
 Website: www.pasternack.com | E-Mail: sales@pasternack.com

PE45327 CAD Drawing

BMA Jack Slide-On Connector Solder Attachment 2 Hole Flange Mount for
RG402, PE-SR402AL, PE-SR402FL, PE-SR402FLJ, PE-SR402TN

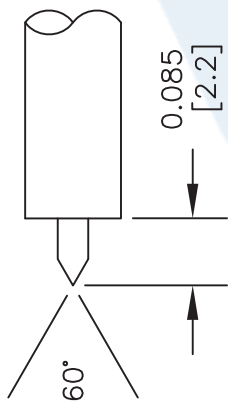
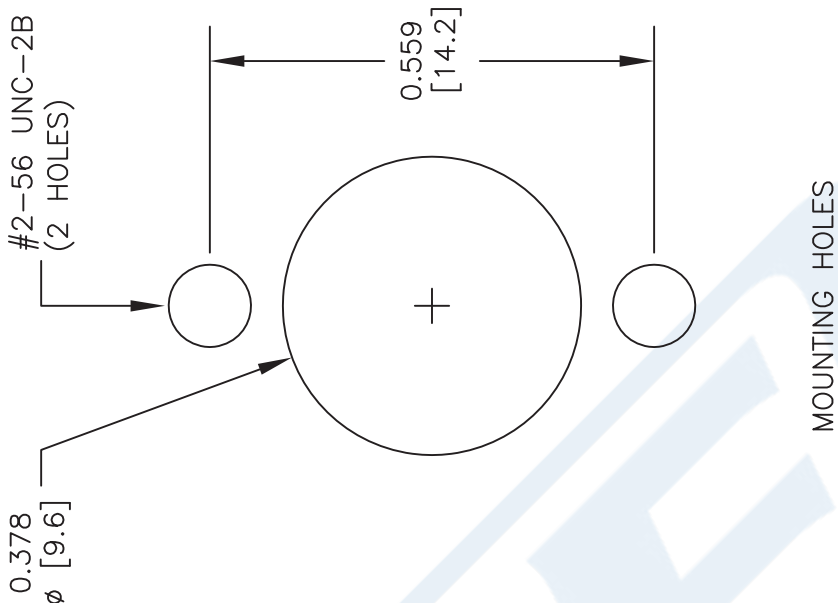

STRIPPING DIMENSIONS

ASSEMBLY PROCEDURES

1. STRIP CABLE AS SHOWN. DO NOT NICK CENTER CONDUCTOR.
2. SLIDE CABLE INTO CONNECTOR INSURING CENTER CONDUCTOR MATES WITH CENTER PIN.
3. OUTER CONDUCTOR BOTTOMS OUT WITH BODY SHOULDER. SOLDER OUTER CONDUCTOR TO BODY.

STANDARD TOLERANCES

.X ±0.2
.XX ±0.1
.XXX ±0.05

*STANDARD TOLERANCES APPLY ONLY TO DIMENSIONS IN INCHES



Pasternack Enterprises, Inc.
P.O. Box 16759 | Irvine | CA | 92623
Phone: (949) 261-1920 | Fax: (949) 261-7451
Website: www.pasternack.com | E-Mail: sales@pasternack.com

DWG TITLE

PE45327

NOTES:
1. UNLESS OTHERWISE SPECIFIED ALL DIMENSIONS ARE NOMINAL.
2. ALL SPECIFICATIONS ARE SUBJECT TO CHANGE WITHOUT NOTICE AT ANY TIME.
3. DIMENSIONS ARE IN INCHES [mm].

CAGE CODE 53919

CAD FILE 020317

SCALE N/A

SIZE A

2233