

MATERIALS

BODY	BRASS WHITE BRONZE
CONTACT	GOLD PLATED
INSULATOR	PTFE
COUPLING NUT	BRASS NICKEL PLATED

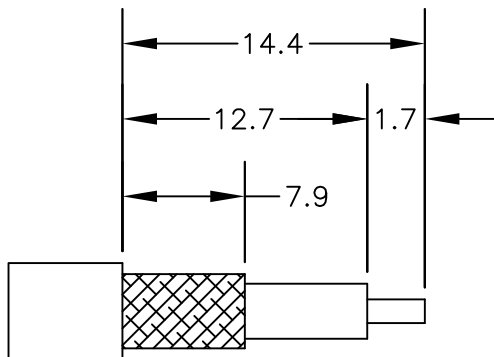
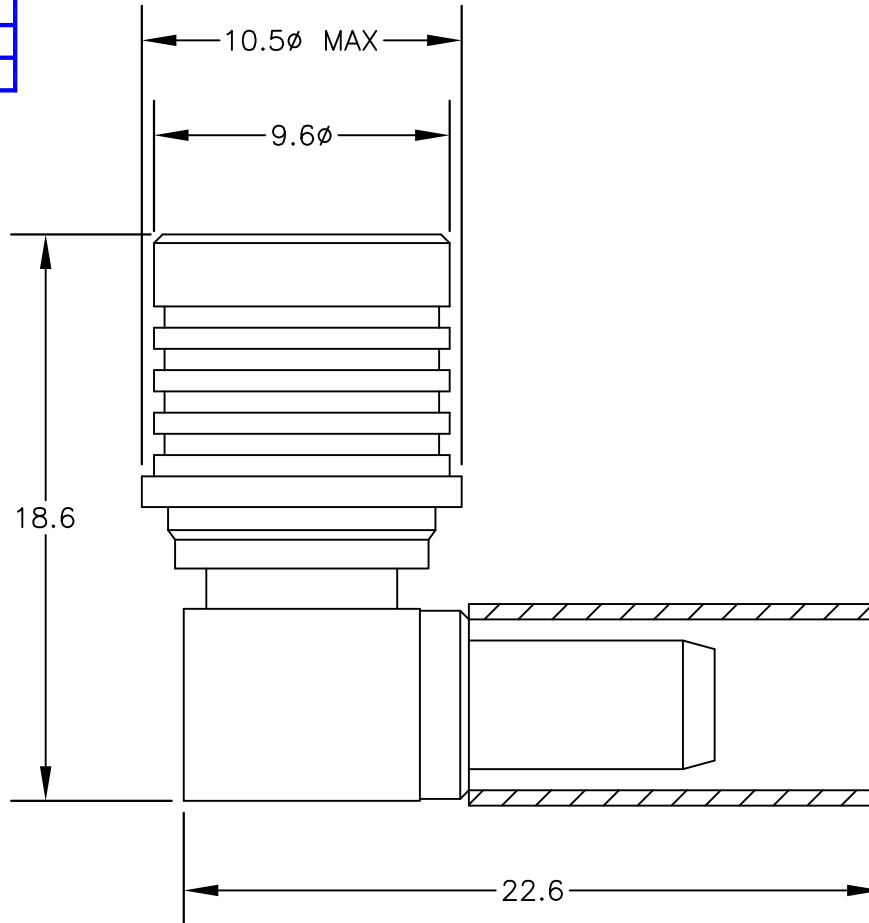

STRIPPING DIMENSIONS

ASSEMBLY PROCEDURES

1. STRIP CABLE AS SHOWN & SLIDE FERRULE OVER CABLE.
2. INSTALL CABLE INTO BODY OF CONNECTOR AND SOFT SOLDER CENTER CONDUCTOR IN PLACE.
3. CRIMP FERRULE & PRESS CAP DOWN.

CRIMP SIZE REQUIRED

FERRULE: 5.41 CRIMP TOOL



PASTERNAK ENTERPRISES, INC.

P.O BOX 16759, IRVINE, CA 92623
PHONE (949) 261-1920 FAX (949) 261-7451

WEB ADDRESS: www.pasternack.com
E-MAIL ADDRESS: sales@pasternack.com

COAXIAL & FIBER OPTICS

DWG TITLE

PE44515

DES.

QMA MALE RIGHT ANGLE, SOLDER-CRIMP
ATTACHMENT FOR RG55, RG142, RG223 &
RG400

SIZE A

FSCM NO. 53919

CAD FILE

042307

SCALE N/A

127

NOTES:

1. UNLESS OTHERWISE SPECIFIED ALL DIMENSIONS ARE NOMINAL.
2. ALL SPECIFICATIONS ARE SUBJECT TO CHANGE WITHOUT NOTICE AT ANY TIME.
3. ALL DIMENSIONS ARE IN mm.