



## Snap-On BMA Jack to TNC Male Cable Using RG316 Coax

### RF Cable Assemblies Technical Data Sheet

PE3C4946

#### Configuration

- Connector 1: Snap-On BMA Jack
- Connector 2: TNC Male
- Cable Type: RG316

#### Features

- Max Frequency 2.5 GHz
- 69% Phase Velocity
- FEP Jacket
- Good VSWR of 1.4:1
- Gold Plated BMA Contacts
- Low Engagement Force BMA interface
- In stock and ready to ship

#### Applications

- General Purpose
- Laboratory Use BMA Cable RF Backplanes
- Blind Mate BMA Test Rack and Panel
- Phased Array Interconnects
- High Speed Switching Networks

#### Description

Pasternack's BMA cable assemblies using RG316/U Coax are part of our full line of RF components available for same-day shipping. These BMA cable assemblies are designed to connect BMA system components, BMA racks, or BMA backplanes, delivering signal frequencies as high as 22 GHz. Our family of BMA cables can also be used to connect switching networks or phase-matched antenna arrays where low loss BMA interconnects are desired. If none of our standard options fit your application, you can specify your own custom BMA cable assembly using Pasternack's online Cable Creator.

Our BMA cable assembly datasheet specifications and drawing with dimensions are shown below in this PDF. Pasternack's broad catalog of RF, microwave and millimeter wave cable assemblies allow designers to configure and customize their signal connections however they like. Whether the need is to provide BMA cabling or blind mate rack connections, Pasternack has the right cable assemblies for the job. Pasternack can also expertly build your custom cable assemblies for you and ship same day.

#### Electrical Specifications

Description	Minimum	Typical	Maximum	Units
Frequency Range	DC		2.5	GHz
VSWR			1.4:1	
Return Loss			15.56	dB
Velocity of Propagation		69		%
Operating Voltage (AC)			250	Vrms
Jacket Spark			2,000	Vrms

Click the following link (or enter part number in "SEARCH" on website) to obtain additional part information including price, inventory and certifications: [Snap-On BMA Jack to TNC Male Cable Using RG316 Coax PE3C4946](#)



## Snap-On BMA Jack to TNC Male Cable Using RG316 Coax

### RF Cable Assemblies Technical Data Sheet

PE3C4946

#### Specifications by Frequency

Description	F1	F2	F3	F4	F5	Units
Frequency	0.1	0.25	0.5	1	2.5	GHz
Insertion Loss (Typ.)	0.11	0.15	0.27	0.38	0.53	dB/ft
	0.36	0.49	0.89	1.25	1.74	dB/m

#### Electrical Specification Notes:

Insertion Loss does not include the loss of the connectors. Insertion Loss is estimated as 0.1 dB per connector.

#### Mechanical Specifications

##### Cable Assembly

Diameter 0.6 in [15.24 mm]

##### Cable

Cable Type RG316  
 Impedance 50 Ohms  
 Inner Conductor Type Stranded  
 Inner Conductor Material and Plating Copper Clad Steel, Silver  
 Dielectric Type PTFE  
 Number of Shields 1  
 Shield Layer 1 Silver Plated Copper Braid  
 Jacket Material FEP, Tan  
 Jacket Diameter 0.098 in [2.49 mm]

#### Connectors

Description	Connector 1	Connector 2
Type	BMA Jack	TNC Male
Impedance	50 Ohms	50 Ohms
Connection Method	Snap-On	
Contact Material and Plating	Beryllium Copper, Gold	Beryllium Copper, Gold
Contact Plating Specification	51.18µ in. minimum	
Dielectric Type	PTFE	Teflon
Outer Conductor Material and Plating	Beryllium Copper, Gold	
Body Material and Plating	Passivated Stainless Steel	Brass, Silver
Coupling Nut Material and Plating	Brass, Silver	

#### Mechanical Specification Notes:

\*All cable assemblies have a length tolerance of 1.5% or ± 3/8", whichever is greater.

Click the following link (or enter part number in "SEARCH" on website) to obtain additional part information including price, inventory and certifications: [Snap-On BMA Jack to TNC Male Cable Using RG316 Coax PE3C4946](#)



## Snap-On BMA Jack to TNC Male Cable Using RG316 Coax

### RF Cable Assemblies Technical Data Sheet

PE3C4946

**Compliance Certifications** (see [product page](#) for current document)

**Plotted and Other Data**

Notes:



Click the following link (or enter part number in "SEARCH" on website) to obtain additional part information including price, inventory and certifications: [Snap-On BMA Jack to TNC Male Cable Using RG316 Coax PE3C4946](#)





Snap-On BMA Jack to TNC Male Cable Using RG316 Coax

RF Cable Assemblies Technical Data Sheet

PE3C4946

Typical Performance Data

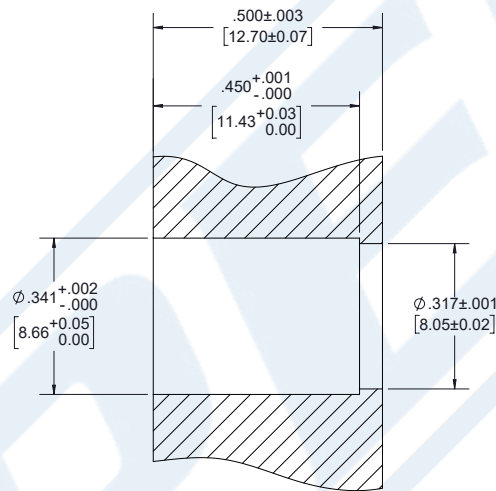

PANEL DRILLING

Click the following link (or enter part number in "SEARCH" on website) to obtain additional part information including price, inventory and certifications: [Snap-On BMA Jack to TNC Male Cable Using RG316 Coax PE3C4946](#)





## Snap-On BMA Jack to TNC Male Cable Using RG316 Coax

### RF Cable Assemblies Technical Data Sheet

PE3C4946

#### How to Order

Part Number Configuration:

**PE3C4946**

- **xx**

**uu**

Unit of Measure:  
 cm = Centimeters  
 <blank> = Inches  
 Length  
 Base Number

Example: PE3C4946-12 = 12 inches long cable  
 PE3C4946-100cm = 100 cm long cable

Snap-On BMA Jack to TNC Male Cable Using RG316 Coax from Pasternack Enterprises has same day shipment for domestic and International orders. Our RF, microwave and millimeter wave products maintain a 99.4% availability and are part of the broadest selection in the industry.

Click the following link (or enter part number in "SEARCH" on website) to obtain additional part information including price, inventory and certifications: [Snap-On BMA Jack to TNC Male Cable Using RG316 Coax PE3C4946](https://www.pasternack.com/bma-jack-tnc-male-rg316u-cable-assembly-pe3c4946-p.aspx)

URL: <https://www.pasternack.com/bma-jack-tnc-male-rg316u-cable-assembly-pe3c4946-p.aspx>

The information contained in this document is accurate to the best of our knowledge and representative of the part described herein. It may be necessary to make modifications to the part and/or the documentation of the part, in order to implement improvements. Pasternack reserves the right to make such changes as required. Unless otherwise stated, all specifications are nominal. Pasternack does not make any representation or warranty regarding the suitability of the part described herein for any particular purpose, and Pasternack does not assume any liability arising out of the use of any part or documentation.

# PE3C4946 CAD Drawing

## Snap-On BMA Jack to TNC Male Cable Using RG316 Coax

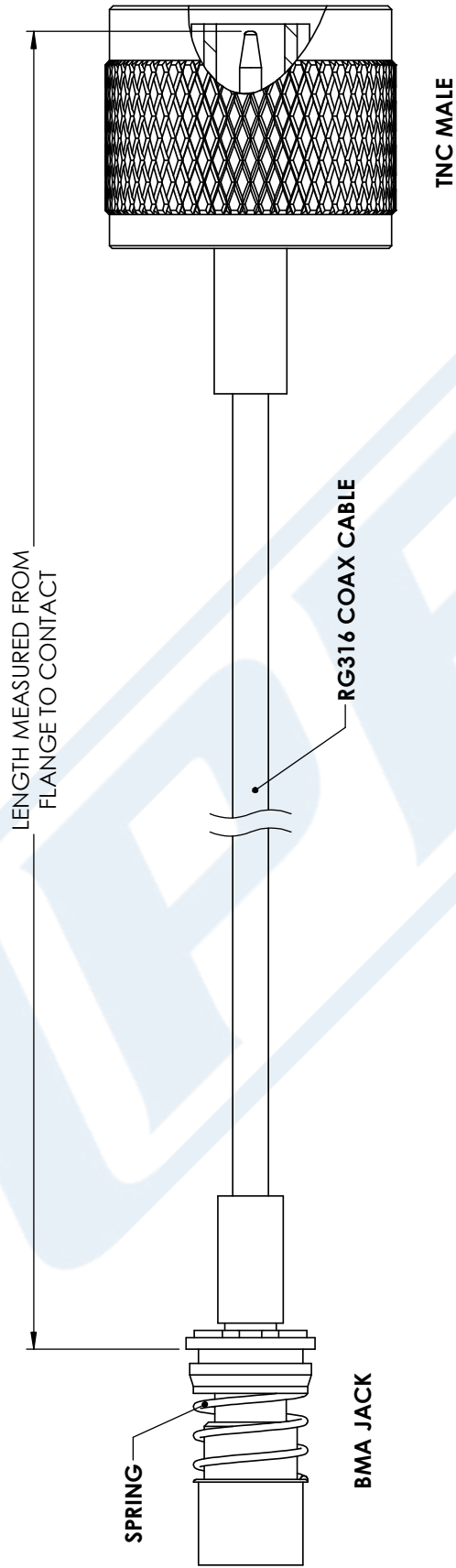

STANDARD TOLERANCES	
.X	±0.2
.XX	±0.01
.XXX	±0.005

\*STANDARD TOLERANCES APPLY ONLY TO DIMENSIONS IN INCHES

**PE PASTERNAK**  
THE ENGINEER'S RF SOURCE  
 Pasternack Enterprises, Inc.  
 P.O. Box 16759 | Irvine | CA | 92623  
**Phone:** (949) 261-1920 | **Fax:** (949) 261-7451  
**Website:** www.pasternack.com | **E-Mail:** sales@pasternack.com

DWG TITLE	PE3C4946
CAGE CODE	53919

NOTES:	1. UNLESS OTHERWISE SPECIFIED ALL DIMENSIONS ARE NOMINAL.
	2. ALL SPECIFICATIONS ARE SUBJECT TO CHANGE WITHOUT NOTICE AT ANY TIME.
	3. DIMENSIONS ARE IN INCHES [mm].
CAD FILE	01/03/18
SCALE	N/A
SIZE	A
	CN2245