



## 11 dBm P1dB, DC to 2 GHz, DC Coupled Amplifier, 8 dB Gain, 25 dBm IP3, SMA

### TECHNICAL DATA SHEET

PE15A86000

The PE15A86000 is general purpose DC coupled amplifier operates with 3 dB Bandwidth of 2000 MHz, designed for wideband signal processing applications. The amplifier offers +11 dBm typ of P1dB, 8 dB typ Gain, IP3 +25 dBm typ with Input/output ports are matched for 50 ohms. This DC coupled amplifier requires a dual input voltage supply of  $\pm 12$  VDC and includes built-in voltage regulation, is unconditionally stable and operates over the temperature range of  $-40^{\circ}\text{C}$  and  $+85^{\circ}\text{C}$ . The Rugged compact package assembly is designed to meet MIL-STD-202 environmental test conditions for Humidity, Shock, Vibration and Altitude.

#### Features

- 3 dB Bandwidth of 2000 MHz
- P1dB: +11 dBm typ
- Small Signal Gain: 8 dB typ
- IP3: 30 dBm min
- 50 Ohm Input and Output Matched
- $-40$  to  $+85^{\circ}\text{C}$  Operating Temperature
- Unconditionally Stable
- Dual Input Voltage Supply of  $\pm 12$  VDC
- Built-in Voltage Regulator

#### Applications

- Laboratory Applications
- R&D Labs
- Military Radio
- Radar Systems
- Telecom Infrastructure
- Test Instrumentation
- Military & Space
- Communication Systems
- Wireless Communication
- Microwave Radio Systems
- Cellular Base Stations
- Low Noise Amplifier
- General Purpose Amplification
- General Purpose Wireless
- Wideband Gain Block
- IF Amplifier/RF Driver Amplifier
- RF Wideband Front Ends
- RF Pre-amplification

#### Electrical Specifications (TA = $+25^{\circ}\text{C}$ , DC Voltage = 9 and 12 Volts, DC Current = 45mA)

Description	Minimum	Typical	Maximum	Units
Frequency Range	DC		2	GHz
Small Signal Gain		8		dB
Output 3rd Intercept Point		+25		dBm
Noise Figure		16	18	dB
Slew Rate (Vout = 1.5 V/Step)		5,500		us/V
Settling Time		600		ps
Operating DC Voltage	9	12	15	Volts
Operating DC Current		45	60	mA
Operating Temperature Range	-40		+85	$^{\circ}\text{C}$

#### RF Characteristic

Description	Band 1	Band 2	Band 3	Units
Frequency Range	DC to 0	0 to 0.5	0.5 to 1	GHz
Output at 1 dB Compression Point	+12.4	+11.3	+6.5	dBm

Click the following link (or enter part number in "SEARCH" on website) to obtain additional part information including price, inventory and certifications: [11 dBm P1dB, DC to 2 GHz, DC Coupled Amplifier, 8 dB Gain, 25 dBm IP3, SMA PE15A86000](#)



11 dBm P1dB, DC to 2 GHz, DC Coupled  
Amplifier, 8 dB Gain, 25 dBm IP3, SMA

TECHNICAL DATA SHEET

PE15A86000



Click the following link (or enter part number in "SEARCH" on website) to obtain additional part information including price, inventory and certifications: [11 dBm P1dB, DC to 2 GHz, DC Coupled Amplifier, 8 dB Gain, 25 dBm IP3, SMA PE15A86000](#)



11 dBm P1dB, DC to 2 GHz, DC Coupled  
Amplifier, 8 dB Gain, 25 dBm IP3, SMA

TECHNICAL DATA SHEET

PE15A86000

Parameter	Unit	Minimum	Typical	Maximum
Frequency Range (-3dB)	MHz	0		2000
Power Gain f = 0Hz	dB		8.0	
f = 100MHz	dB		8.0	
f = 500MHz	dB		8.0	
f = 1000MHz	dB		7.8	
f = 1500MHz	dB		7.3	
f = 2000MHz	dB		5.0	
Voltage Gain (RL=∞) f = 0 Hz			+5	
P <sub>1dB</sub> f = 10KHz	dBm		+12.4	
f = 100MHz	dBm		+12.4	
f = 500MHz	dBm		+11.3	
f = 1000MHz	dBm		+6.5	
f = 1500MHz	dBm		+2.0	
f = 2000MHz	dBm		-2.5	
IP3 f = 100MHz	dBm		+39	

Click the following link (or enter part number in "SEARCH" on website) to obtain additional part information including price, inventory and certifications: [11 dBm P1dB, DC to 2 GHz, DC Coupled Amplifier, 8 dB Gain, 25 dBm IP3, SMA PE15A86000](#)



11 dBm P1dB, DC to 2 GHz, DC Coupled  
Amplifier, 8 dB Gain, 25 dBm IP3, SMA

TECHNICAL DATA SHEET

PE15A86000

f = 300MHz	dBm		+32	
f = 500MHz	dBm		+27	
Slew Rate Vout = 1.5V Step	µs/V		5500	
Output Voltage Swing f = 100MHz	Vp-p		1.6	
f = 500MHz	Vp-p		1.5	
Output Current f = 100MHz	mA		±16	
Output Voltage* Pin= 0dBm				
f = 100KHz RL=∞	Vp-p		3.3	
f = 100MHz RL=∞	Vp-p		2.9	
f = 500MHz RL=∞	Vp-p		1.7	
Second Harmonic Distortion	dBc		-66	
Third Harmonic Distortion	dBc		-81	
Third Order Intermodulation IMD3	dBc		-73	
Reserve Isolation	dB		-50	
Input Offset Voltage	mV		2.0	
Average Offset Voltage Drift	µV/°C		±20	
Input Bias Current	µA			7
Average Bias Current Drift	nA/°C		±55	
Input Voltage Noise f = 1MHz	nV/√Hz		2.5	
Noise Figure f = 100MHz	dB		16	
Setting Time	ns		0.6	
Return Loss f = 500MHz Input	dB		-25	
Output	dB		-26	
DC Power Supply	V	±8	±12	±18
Supply Current	mA		±45	
Operating Temperature	°C	-40		+85
Size	inch	1.25" x 1.25" x 0.56"		
Weight	Oz.	1.5		

**Absolute Maximum Rating**

Click the following link (or enter part number in "SEARCH" on website) to obtain additional part information including price, inventory and certifications: [11 dBm P1dB, DC to 2 GHz, DC Coupled Amplifier, 8 dB Gain, 25 dBm IP3, SMA PE15A86000](#)



11 dBm P1dB, DC to 2 GHz, DC Coupled  
Amplifier, 8 dB Gain, 25 dBm IP3, SMA

TECHNICAL DATA SHEET

PE15A86000

Parameter	Rating	Units
RF Input Power	+13	dBm
Input DC Voltage	±3	V
Supply Voltage	±20	V
Operating Temperature	-40 to +85	°C
Storage Temperature	-55 to +125	°C



ESD Sensitive Material,  
Transport material in  
Approved ESD bags.  
Handle only in approved  
ESD Workstation.

**Mechanical Specifications**

**Size**

Length 1.25 in [31.75 mm]  
Width 1.25 in [31.75 mm]  
Height 0.56 in [14.22 mm]

Input Connector SMA Female  
Output Connector SMA Female

**Environmental Specifications**

**Temperature**

Operating Range -40 to +85 deg C  
Storage Range -55 to +125 deg C

Humidity MIL-STD-202F, Method 103B, Condition B  
Shock MIL-STD-202F, Method 213B, Condition B  
Vibration MIL-STD-202F, Method 204D, Condition B  
Altitude MIL-STD-202F, Method 105C, Condition B

**Compliance Certifications** (see [product page](#) for current document)

**Plotted and Other Data**

Notes:

- Values at +25 °C, sea level
- ESD Sensitive Material, Transport material in Approved ESD bags. Handle only in approved ESD Workstation.

Click the following link (or enter part number in "SEARCH" on website) to obtain additional part information including price, inventory and certifications: [11 dBm P1dB, DC to 2 GHz, DC Coupled Amplifier, 8 dB Gain, 25 dBm IP3, SMA PE15A86000](#)



## 11 dBm P1dB, DC to 2 GHz, DC Coupled Amplifier, 8 dB Gain, 25 dBm IP3, SMA

### TECHNICAL DATA SHEET

PE15A86000

#### Amplifier Power-up Precautions

- 1.) Confirm that proper ESD precautions and controls are always in place before handling any Amplifier module.
- 2.) Confirm adequate thermal management is in place to effectively dissipate heat away from the Amplifier package. The Amplifier operational baseplate temperature must be within the operational temperature range stated in the Amplifier datasheet. Depending on the design and thermal requirements, using a heatsink with cooling fan is always recommended for safe reliable operation. A heat sink without a cooling fan may also be used. Damage caused from overheating will void the warranty.
- 3.) Confirm adequate system grounding is established. The DC power supply and Amplifier must have a common ground in order to operate properly.
- 4.) Power Amplifiers may require additional DC Current when initially powered-up. Depending on the design, the input current draw could range from an additional 10% to 100% above the maximum rated DC current of the Amplifier. This varies based on product part number.
- 5.) Confirm the DC power supply, if limited, is set to allow for additional start-up current that's rated for the Power Amplifier.
- 6.) Confirm the system is designed and calibrated for 50 ohms. Any impedance mismatch may cause performance issues.
- 7.) Perform a CALIBRATION (if required) with the loads before connecting the Amplifier to the Network Analyzer to ensure proper performance.
- 8.) Use a fixed attenuator between the signal source and input port of the Amplifier to optimize the input VSWR match.
- 9.) Confirm the input power level at the input port of the amplifier does not exceed the maximum rated limit for input power (as stated in the Amplifier datasheet).  
 $P_{in}$  for Small Signal Gain = P1dB-SSG-10 dB  
 $P_{in}$  for P1dB = P1dB-SSG+1 dB
- 10.) Confirm the Network Analyzer is always connected to the Amplifier first before DC power is applied to the Amplifier.
- 11.) As long as the input and output ports of the amplifier are connected to a 50Ohm load and RF signal power is applied, the Amplifier can be powered up with DC voltage.
- 12.) Confirm the Amplifier output load is matched for a 50 Ohm impedance and will not exceed the maximum rated VSWR or Return Loss limit for the Amplifier. Exceeding the maximum rated VSWR or Return Loss limit will result in reflected signal power that could damage the Amplifier and void the warranty.
- 13.) **Power Amplifier connected to an Antenna for signal transmission** - It's strongly recommended to use a high power fixed attenuator pad or an Isolator between the output port of the Amplifier and input port to the antenna. Any reflected signal power due to impedance mismatch will likely damage the Amplifier and void the warranty.
- 14.) The attenuator or isolator used at the output port of the Amplifier must be rated to handle the output power level and operational frequency band of the amplifier.

Click the following link (or enter part number in "SEARCH" on website) to obtain additional part information including price, inventory and certifications: [11 dBm P1dB, DC to 2 GHz, DC Coupled Amplifier, 8 dB Gain, 25 dBm IP3, SMA PE15A86000](#)



11 dBm P1dB, DC to 2 GHz, DC Coupled  
Amplifier, 8 dB Gain, 25 dBm IP3, SMA

TECHNICAL DATA SHEET

PE15A86000

Typical Performance Data

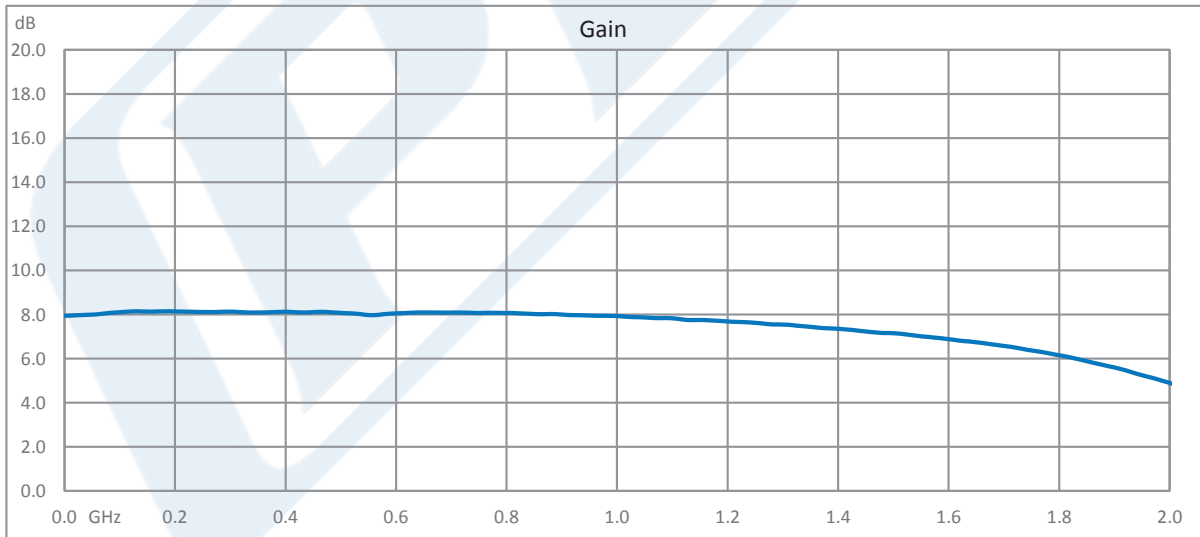
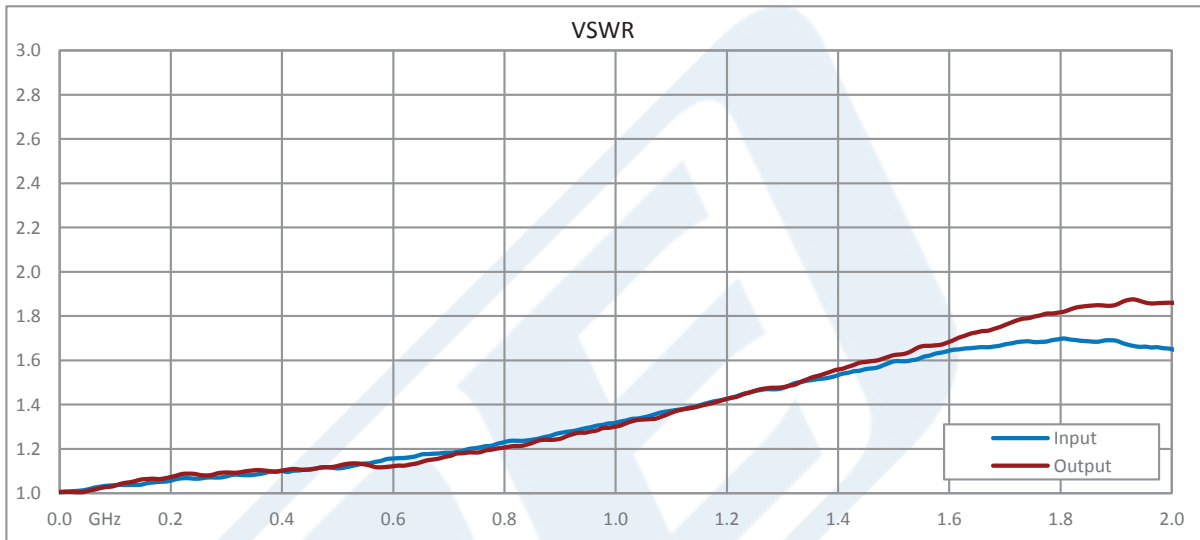

Click the following link (or enter part number in "SEARCH" on website) to obtain additional part information including price, inventory and certifications: [11 dBm P1dB, DC to 2 GHz, DC Coupled Amplifier, 8 dB Gain, 25 dBm IP3, SMA PE15A86000](#)



11 dBm P1dB, DC to 2 GHz, DC Coupled  
Amplifier, 8 dB Gain, 25 dBm IP3, SMA

TECHNICAL DATA SHEET

PE15A86000

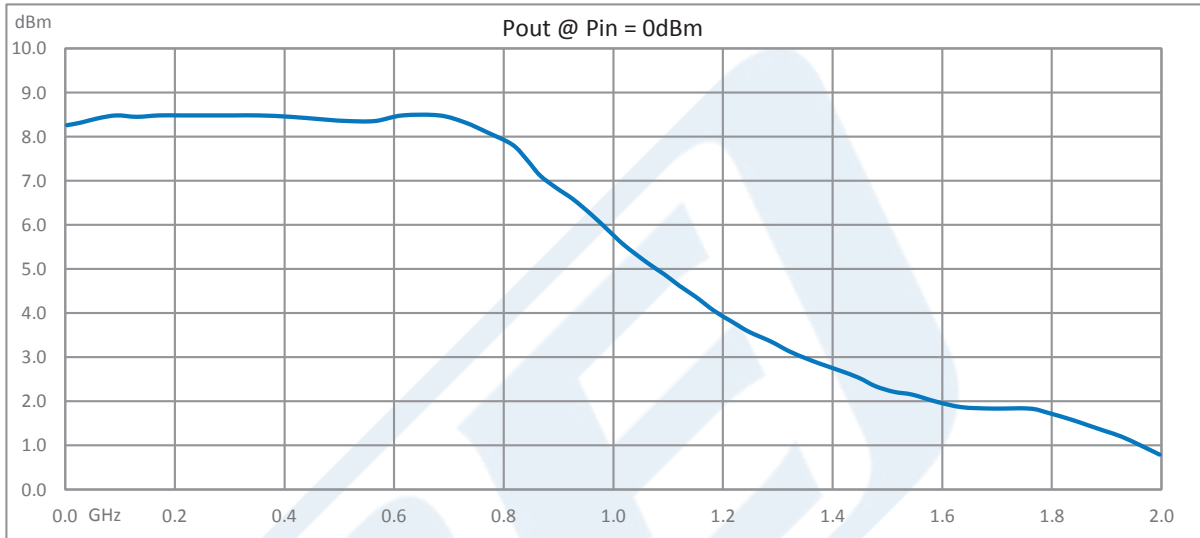

11 dBm P1dB, DC to 2 GHz, DC Coupled Amplifier, 8 dB Gain, 25 dBm IP3, SMA from Pasternack Enterprises has same day shipment for domestic and International orders. Our RF, microwave and millimeter wave products maintain a 99.4% availability and are part of the broadest selection in the industry.

Click the following link (or enter part number in "SEARCH" on website) to obtain additional part information including price, inventory and certifications: 11 dBm P1dB, DC to 2 GHz, DC Coupled Amplifier, 8 dB Gain, 25 dBm IP3, SMA PE15A86000

URL: <https://www.pasternack.com/2-ghz-gain-block-amplifier-8-db-gain-16-db-sma-pe15a86000-p.aspx>

The information contained in this document is accurate to the best of our knowledge and representative of the part described herein. It may be necessary to make modifications to the part and/or the documentation of the part, in order to implement improvements. Pasternack reserves the right to make such changes as required. Unless otherwise stated, all specifications are nominal. Pasternack does not make any representation or warranty regarding the suitability of the part described herein for any particular purpose, and Pasternack does not assume any liability arising out of the use of any part or documentation.



# PE15A86000 CAD Drawing

11 dBm P1dB, DC to 2 GHz, DC Coupled Amplifier, 8 dB Gain, 25 dBm IP3, SMA

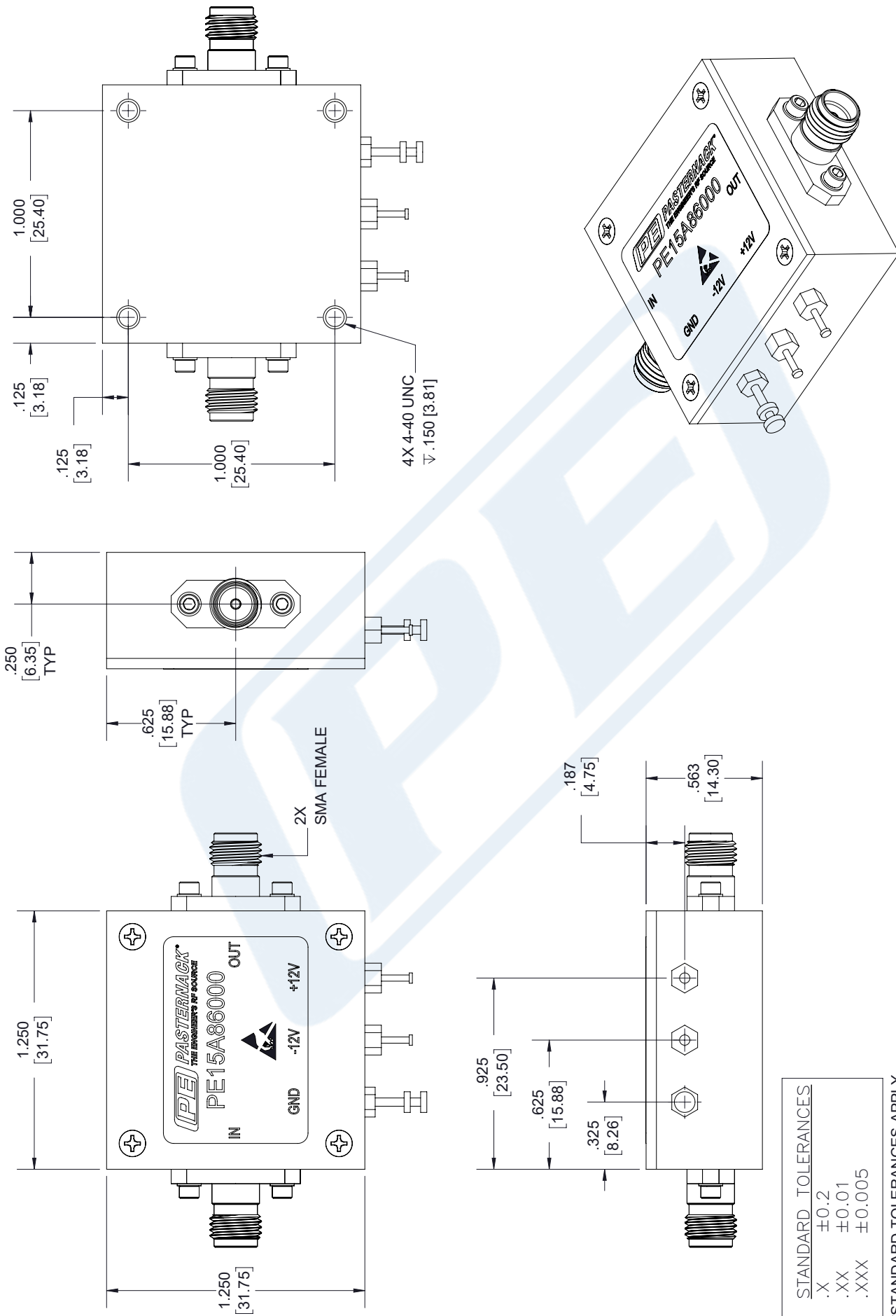

### STANDARD TOLERANCES

- .X ±0.2
- .XX ±0.01
- .XXX ±0.005

\*STANDARD TOLERANCES APPLY ONLY TO DIMENSIONS IN INCHES



THE ENGINEER'S RF SOURCE

Pasternack Enterprises, Inc.

P.O. Box 16759 | Irvine | CA | 92623

Phone: (949) 261-1920 | Fax: (949) 261-7451

Website: [www.pasternack.com](http://www.pasternack.com) | E-Mail: [sales@pasternack.com](mailto:sales@pasternack.com)

DWG TITLE

PE1586000

NOTES:  
 1. UNLESS OTHERWISE SPECIFIED ALL DIMENSIONS ARE NOMINAL.  
 2. ALL SPECIFICATIONS ARE SUBJECT TO CHANGE WITHOUT NOTICE AT ANY TIME.  
 3. DIMENSIONS ARE IN INCHES [mm].

CAGE CODE 53919

CAD FILE 04/23/18

SCALE N/A

SIZE A

7361